

I. Connector assignment EOT-3

Connector 7-pole (electronics and oscillation motor):

PIN	Cable colour	Function / description	Remark
1	red	+6 to +24V DC electronics for position sensor	A
2	black	0V DC electronics for position sensor	
3	yellow	Relay - Base	B
4	brown	Relay - Output A	
5	blue	Relay - Output B	
6	red	+12V DC to +20V DC oscillation motor	C
7	black	0V DC oscillation motor	

Connector 8-pole (stepper motor):

PIN	Cable colour	Function / description	Remark																																																																					
1	black	<table border="1"> <thead> <tr> <th colspan="4">TYPE OF CONNECTION (EXTERN)</th> <th colspan="3">MOTOR</th> </tr> <tr> <th rowspan="2">UNIPOLAR</th> <th colspan="3">BIPOLAR</th> <th rowspan="2">CONNECTOR PIN NO. ↗</th> <th rowspan="2">LEADS</th> <th rowspan="2">WINDING</th> </tr> <tr> <th>1WINDING</th> <th>SERIAL</th> <th>PARALLEL</th> </tr> </thead> <tbody> <tr> <td>A —</td> <td>A —</td> <td>A —</td> <td>A —</td> <td>1</td> <td>BLK</td> <td rowspan="2">A</td> </tr> <tr> <td>COM —</td> <td>A —</td> <td>—</td> <td>—</td> <td>3</td> <td>BLK/WHT</td> </tr> <tr> <td>A\ —</td> <td>—</td> <td>A\ —</td> <td>A\ —</td> <td>2</td> <td>GRN/WHT</td> <td rowspan="2">A\</td> </tr> <tr> <td>B —</td> <td>B —</td> <td>B —</td> <td>B —</td> <td>4</td> <td>GRN</td> </tr> <tr> <td>B\ —</td> <td>—</td> <td>B\ —</td> <td>B\ —</td> <td>5</td> <td>RED</td> <td rowspan="2">B</td> </tr> <tr> <td>COM —</td> <td>B —</td> <td>—</td> <td>—</td> <td>7</td> <td>RED/WHT</td> </tr> <tr> <td>B\ —</td> <td>—</td> <td>B\ —</td> <td>B\ —</td> <td>6</td> <td>BLU/WHT</td> <td rowspan="2">B\</td> </tr> <tr> <td>—</td> <td>—</td> <td>—</td> <td>—</td> <td>8</td> <td>BLU</td> </tr> </tbody> </table>	TYPE OF CONNECTION (EXTERN)				MOTOR			UNIPOLAR	BIPOLAR			CONNECTOR PIN NO. ↗	LEADS	WINDING	1WINDING	SERIAL	PARALLEL	A —	A —	A —	A —	1	BLK	A	COM —	A —	—	—	3	BLK/WHT	A\ —	—	A\ —	A\ —	2	GRN/WHT	A\	B —	B —	B —	B —	4	GRN	B\ —	—	B\ —	B\ —	5	RED	B	COM —	B —	—	—	7	RED/WHT	B\ —	—	B\ —	B\ —	6	BLU/WHT	B\	—	—	—	—	8	BLU	D
TYPE OF CONNECTION (EXTERN)				MOTOR																																																																				
UNIPOLAR	BIPOLAR			CONNECTOR PIN NO. ↗	LEADS	WINDING																																																																		
	1WINDING		SERIAL				PARALLEL																																																																	
A —	A —		A —	A —	1	BLK	A																																																																	
COM —	A —		—	—	3	BLK/WHT																																																																		
A\ —	—		A\ —	A\ —	2	GRN/WHT	A\																																																																	
B —	B —		B —	B —	4	GRN																																																																		
B\ —	—	B\ —	B\ —	5	RED	B																																																																		
COM —	B —	—	—	7	RED/WHT																																																																			
B\ —	—	B\ —	B\ —	6	BLU/WHT	B\																																																																		
—	—	—	—	8	BLU																																																																			
2	green / white																																																																							
3	black / white																																																																							
4	green																																																																							
5	red																																																																							
6	blue / white																																																																							
7	Red / white																																																																							
8	blue																																																																							

Warning !

The notes following on the next page must be observed carefully.



II. Remarks to the connector assignment concerning EOT-3

Remark	Description
A	The electronic system for the position sensor has to be supplied with a direct current of 6V to 24V. Electronics have to be fused externally; the maximum current must not exceed 500mA
B	The position sensor controls an integrated relay that can be used by the supervising CNC controller as a limit or reference switch: <ul style="list-style-type: none"> • Once the blade has reached the homing point during a reference run, there is contact between PIN3 and PIN5 of the 7-pole M16 connector. • If the blade is located outside the reference position, there is contact between PIN3 and PIN4 of the 7-pole M16 connector. • Depending on the applied CNC controller, the integrated relay can be used as a normally closed switch (NC) or as a normally open switch (NO). • The switching voltage of the relay must not exceed 24V DC; the maximum switching current must not exceed 500mA.
C	The nominal voltage of the installed oscillation motor is indicated with 12V DC. This voltage effects a theoretical oscillation frequency of 3500 strokes per minute. An increasing voltage induces a higher oscillation frequency at a higher current. The DC motor has to be fused externally; the maximum current of the drive motor must not exceed 2.8 ampere.
D	The connection of the stepper motor depends on the driver used. The following documentation has to be observed carefully. Stepper motor and stepper controller have to be fused externally.

Warning !



The electrical and mechanical connection of the processing unit has to be done with utmost accuracy by an expert only. It is not allowed to put the unit in operation before all necessary and required country-specific safety regulations have been observed and checked carefully. Only the operator of the facility (i.e. machining system) is responsible for observing all relevant safety regulations.

III. Stepper motor specifications

Front view and mounting

Side view

Rear view

SPECIFICATION	CONNECTION		BIPOLAR		PERMISSIBLE RADIAL+AXIAL FORCE	
	UNIPOLAR OR BIPOLAR-1 WINDING	PARALLEL	SERIAL	PARALLEL	ROTOR SPRING-MOUNTED IN AXIAL DIRECTION	ROTOR SPRING WASHER BEARING
VOLTAGE (VDC)	4.8					
AMPS/PHASE	2.0		1.41	2.82		
RESISTANCE/PHASE (Ohms) @25°C	2.4±10%		4.8±10%	1.2±10%		
INDUCTANCE/PHASE (mH) @1KHz	6.7±20%		26.8±20%	6.7±20%		
HOLDING TORQUE (Nm) [lb-in]	1.27 [11.28]		1.77 [15.62]	1.77 [15.62]		
DETENT TORQUE (Nm) [lb-in]	0.068 [0.602]					
STEP ANGLE (°)	0.9					
STEP ACCURACY (NON-ACCUM)	±5%					
ROTOR INERTIA (kg-m²) [lb-in²]	4.8x10 ⁻⁵ [0.164]					
WEIGHT (kg) [lb]	1.0 [2.2]					
TEMPERATURE RISE: MAX.80°C (MOTOR STANDSTILL; FOR 2 PHASE ENERGIZED)						
AMBIENT TEMPERATURE -10°~ 50°C [14°F ~ 122°F]						
INSULATION RESISTANCE 100 MΩhm (UNDER NORMAL TEMPERATURE AND HUMIDITY)						
INSULATION CLASS B 130° [266°F]						
DIELECTRIC STRENGTH 500VAC FOR 1 MIN. (BETWEEN THE MOTOR COILS AND THE MOTOR CASE)						
AMBIENT HUMIDITY MAX. 85% (NO CONDENSATION)						

TYPE OF CONNECTION (EXTERN)		CONNECTION		MOTOR	
UNIPOLAR	BIPOLAR	CONNECTION	PARALLEL	LEADS	WINDING
TWINDING	SERIAL	PARALLEL	PIN NO.		
A	A	A	1	BLK	A
A	A	A	3	BLK/WHI	A
COM	A	A	2	GRN/WHI	A
A	A	A	4	GRN	A
B	B	B	5	RED	B
COM	B	B	7	RED/WHI	B
B	B	B	6	BLU/WHI	B
B	B	B	8	BLU	B

FULL STEP 2 PHASE-Ex., WHEN FACING MOUNTING END (X)

STEP	A	B	A'	B'	CW	CCW
1	+	+	-	-	+	-
2	-	+	+	-	-	+
3	-	-	+	+	+	-
4	+	-	-	+	-	+

WIRING DIAGRAM

STEPPING MOTOR

SCALE FREE APVD S.H.a. 19.10.10

X +0.5 CHKD

1PL ±0.2 DRN J.W. 19.10.10 DWG.NO

2PL ±0.1 ANGLE ±30° SIGNATURE DATE

IV. Cable preparation for connectors with crimp contacts

ECOCAM #300100

Cable Connector, M16, 7 pin, female, shieldable, metal housing, cable diameter 8-10,5mm



ECOCAM #300200

Cable Connector, M16, 8 pin, female, shieldable, metal housing, cable diameter 8-10,5mm,



Compatible with socket crimp contacts:



#300300 - 0,14 - 0,25mm² / AWG 26 -24

#300400 - 0,35 - 0,5mm² / AWG 22-20

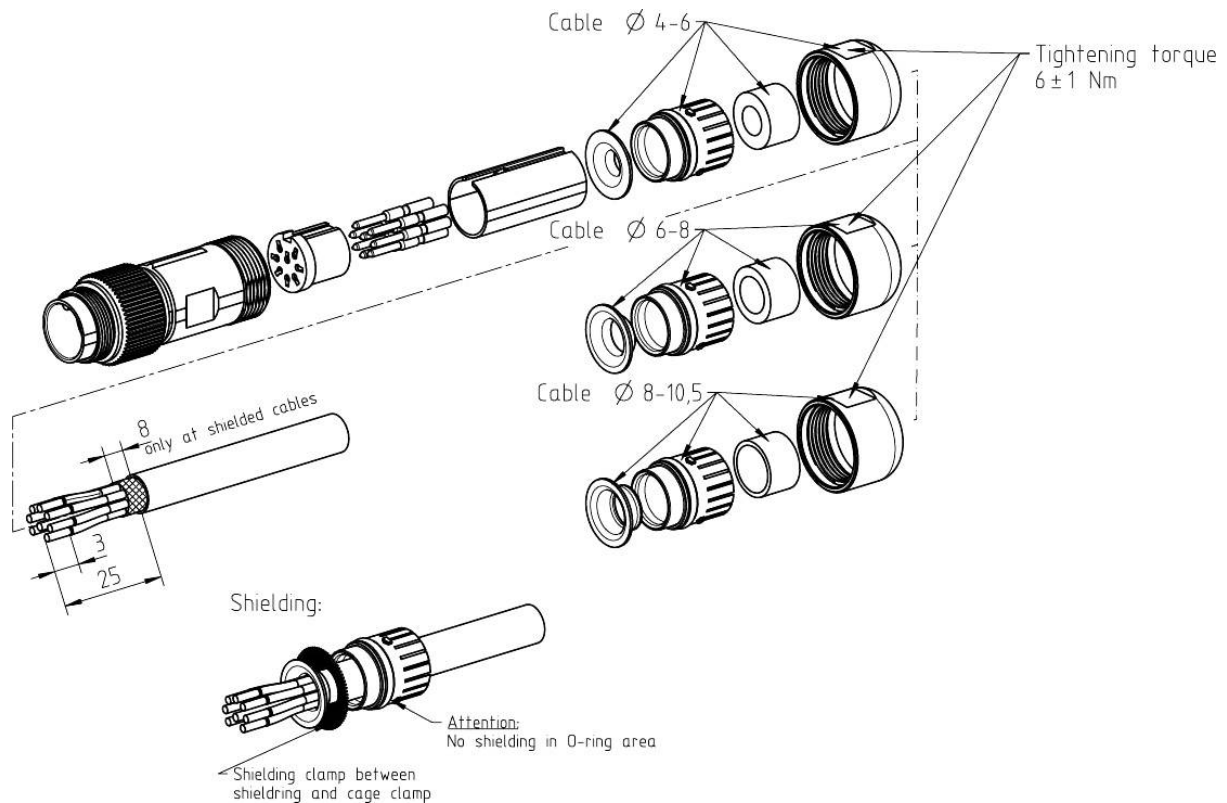
#300500 - 0,75 - 1,0mm² / AWG18



V. Overview of socket crimp contacts for cable connectors

Order number	Connecting range	Wire Gauge		Stripping length	Crimp height (Average values)	Crimp Retention force DIN EN 60352-2
		mm ²	mm ² AWG			
#300100 	0,14 - 0,25	0,14		3,0 + 0,5	0,86 - 0,9	18
			24			28
		0,25			0,91 - 0,97	32
#300200 	0,35 - 0,50	0,35	22	3,0 + 0,5	0,90 - 1,06	40
		0,50	20		0,95 - 1,11	60
#300300 	0,75 - 1,00	0,75		3,5 + 1,0	1,33 - 1,50	85
			18			90
		1,00			1,36 - 1,53	108

© Copyright

ECOCAM CNC - Inh. R. Skowron

All previous versions lose their validity with this document. The information in this document is subject to change without notice. All rights reserved. No part of this document may be reproduced or transmitted in any form or by any means, electronic or mechanical, including photocopying, recording or otherwise, without the express written permission of the copyright owner. Although every care has been taken to avoid mistakes or printing errors, these cannot be ruled out. We would be grateful for any suggestions for improvements or information on possible mistakes or unclear formulation. 01.10.2015